

AMC825-4



AMC825-4

Key Features

- The AMC825-4 module provides real time simulation of up to Four CAN bus nodes concurrently.
- AMC825-4 Transmitter operation allows users to fully program all relevant fields of the CAN bus message protocol.
- The cards have integrated transbus receivers which are compliant with the ISO11898-2 high speed specification.
- The cards obtain an on board IRIG-B decoder with 1m resolution and an automatic free wheeling detection.
- The modules are supplied with an Application Programming Interface (API) and Driver Software compatible with Windows, Linux and VxWorks.

General Overview

The AMC825-4 Mezzanine Card (PMC) can work with either full functionality as a CAN node for testing and simulating or in 'listening only' mode for monitoring and recording purposes of Avionics CAN bus (ARINC429) applications on up to four electrically isolated CAN bus nodes concurrently. All nodes are in conformance with the ISO11898-1/-2 standard. They are accessible by software separately and can be used as four independent CAN bus nodes.

An onboard IRIG-B time decoder allows users to accurately synchronize single or multiple modules to a common time source.

All supported signals are available through a 25-pin D-Sub connector.

The AMC825-4 module consists of FPGA based CAN Interface Controllers as well as, FPGA based 32-bit Microcontroller Core and a separate processor for IRIG-B synchronization with high resolution time stamping. All nodes operate concurrently at CAN bus high speed bit rate of up to 1MBit/s. The FPGA controller can schedule CAN frames in real time onboard to significantly off-load the host processor.

AMC825-4 Diagram

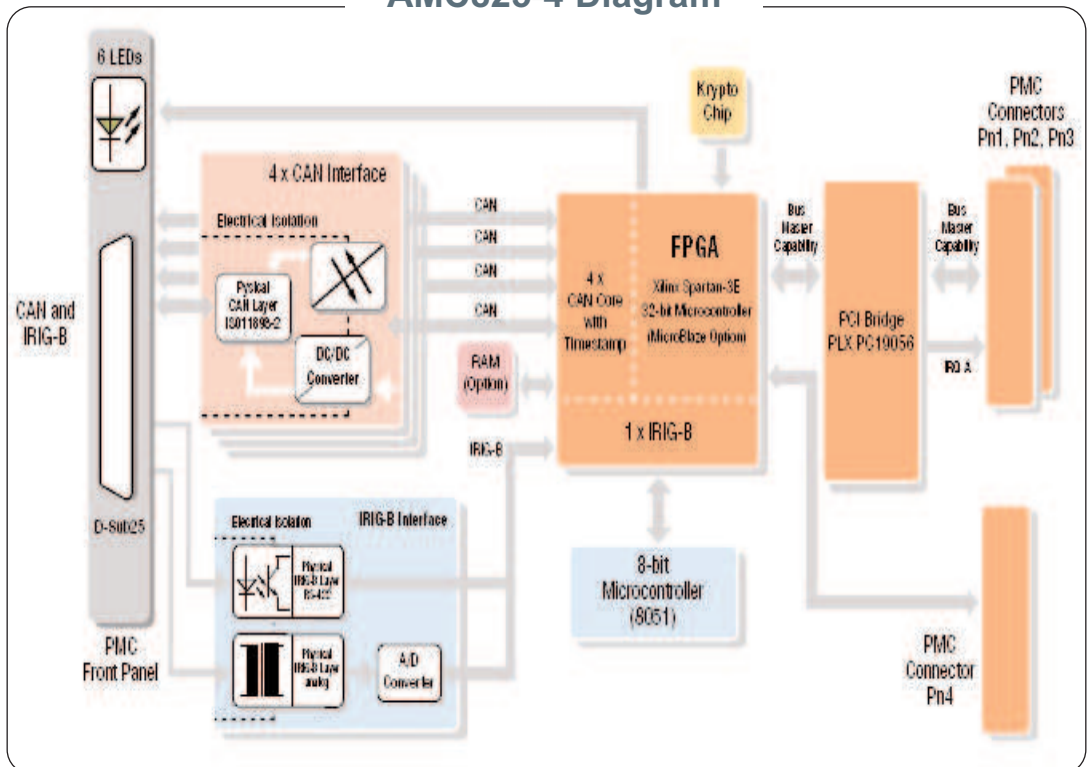

AMC825-4



www.aimusa-online.com



Right On Target

© AIM-USA 2009. Specifications are subject to change without notice.

Technical Data

System Interface: 32-bit; 33/66MHz + 3.3V (+5V tolerant) PCIbus (Rev 2.2) compliant

Processors: FPGA based 32-bit Microcontroller Core and 8051 Processor for IRIG-B handling

Memory: 64MB DRAM (optional)

Encoder/Decoder: FPGA based CAN bus controller core

Time Tagging: 46-bit absolute IRIG-B time code, 1µs resolution; free wheeling

Physical Bus Interface (PBI): Up to 4x ISO11898-2 compliant high speed transceivers. Each CAN bus node is electrically isolated.

Front-I/O Interface:

*One 25-way D-sub (male) connector, providing 4 independent electrically isolated CAN bus nodes, and IRIG-B Time Code Input (analog IRIG-B and RS422)

Rear-I/O Interface:

*1x Standard PMCConnector position Pn4. Includes all signals which are available through Front-I/O Interface
Note: CAN bus is available at TTL level only

PMC/PCI Interface: Pn1, Pn2 for PCI Interface (Rev. 2.2) compliant 32-bit, 33/66MHz, +3.3V (+5V tolerant)

Dimensions: 149mm x 74mm Standard PMC format

Operating Temp. Range:

Standard: 0°C...+50°C ambient
Extended: on request

Storage Temp: -40°C...+85°C ambient

Conduction Cooling available.



Ordering Information

AMC825-4

4 CAN bus nodes ARINC825 on PCI Mezzanine Card (PMC Module), Software programmable CAN bus nodes, IRIG-B bus Stamping

ACP825-4

ARINC825 to PCI module comprising an AMC825-4 installed on a PCI Carrier Card

ACC825-3U-4

ARINC825 to cPCI module (3U) comprising an AMC825-4 installed on an ACC-1, cPCI Carrier Card (3U)

ACC825-6U-X

x=(4, 8)

ARINC825 to cPCI module (6U) comprising one or two AMC825-4 installed on an ACC-2, cPCI Carrier Card (6U)

AVC825-X

x=(4, 8)

ARINC825 to VME module comprising one or two AMC825-4 installed on an ACC-2, VME Carrier Card

On Request

Ready made adapter cable (2.0m): from 25-way D-Sub (male) connector to four 9-way D-Sub (male) connectors with CAN open compliant pin assignment and separate 9-way D-Sub (female) connector for IRIG-B input

AIM-USA

3703 North 200th St.
Omaha, NE 68022

Tel: 1-866-AIM-1553
1-402-763-9644

Fax: 1-402-763-9645

salesusa@aimusa-online.com

www.aimusa-online.com